

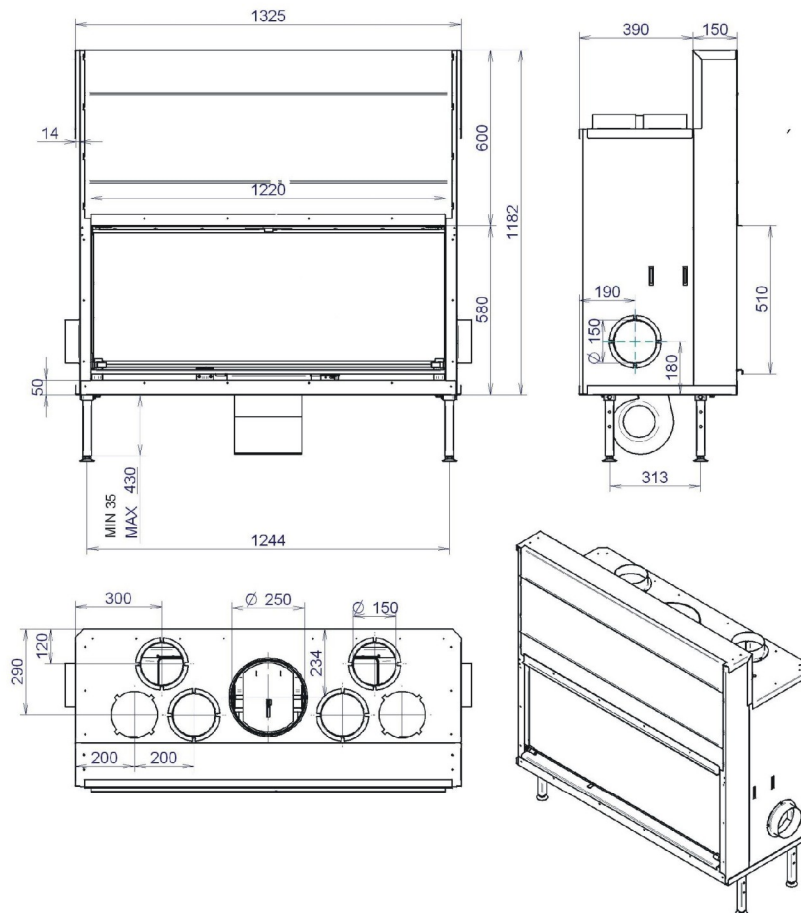

Splend[®]
CONCEPT
1300H



Características complementares:

Emissão de CO: 0,08%

Rendimento: 72,5%

Potência calorífica: 18 kW

Temperatura de combustão: 260° C

Peso: 285 kg

Combustível: Lenha

Distância mínima de materiais
adjacente: 800mm



Porta de Abertura Vertical (guilhotina)



Regulador de Combustão Automático



Cortina de Ar



Alimentação Directa de Ar

Classificado na classe 1 conforme a Norma EN 13229

Certificado e aprovado